



# NINGBO BRITISH INTERNATIONAL SCHOOL

**Weekly Newsletter 8**  
**October 25th, 2024**



# NBIS UNITED NATIONS DAY

OCTOBER 25th, 2024

UNITY IN DIVERSITY: HIGHLIGHTS FROM NBIS UN DAY 2024



The annual UN Day celebration at NBIS took place on October 25, 2024, as scheduled. Despite the persistent rain, the enthusiasm of the NBIS community for celebrating global cultures remained undiminished. Since its inception in 2010, the UN Day event has become one of NBIS's iconic celebrations, with its scale and participation continuously expanding. Each year, students, parents, and teachers from around the world come together to showcase the vibrant cultures of various nations. Whether through food, traditional attire, or performances, the diverse activities allow all participants to experience the richness of different cultures firsthand. In many ways, NBIS serves as a microcosm of the world, bringing together a multicultural community from over 50 countries and regions, where cultures interweave and interact, actively promoting understanding, respect, and celebration of diversity.



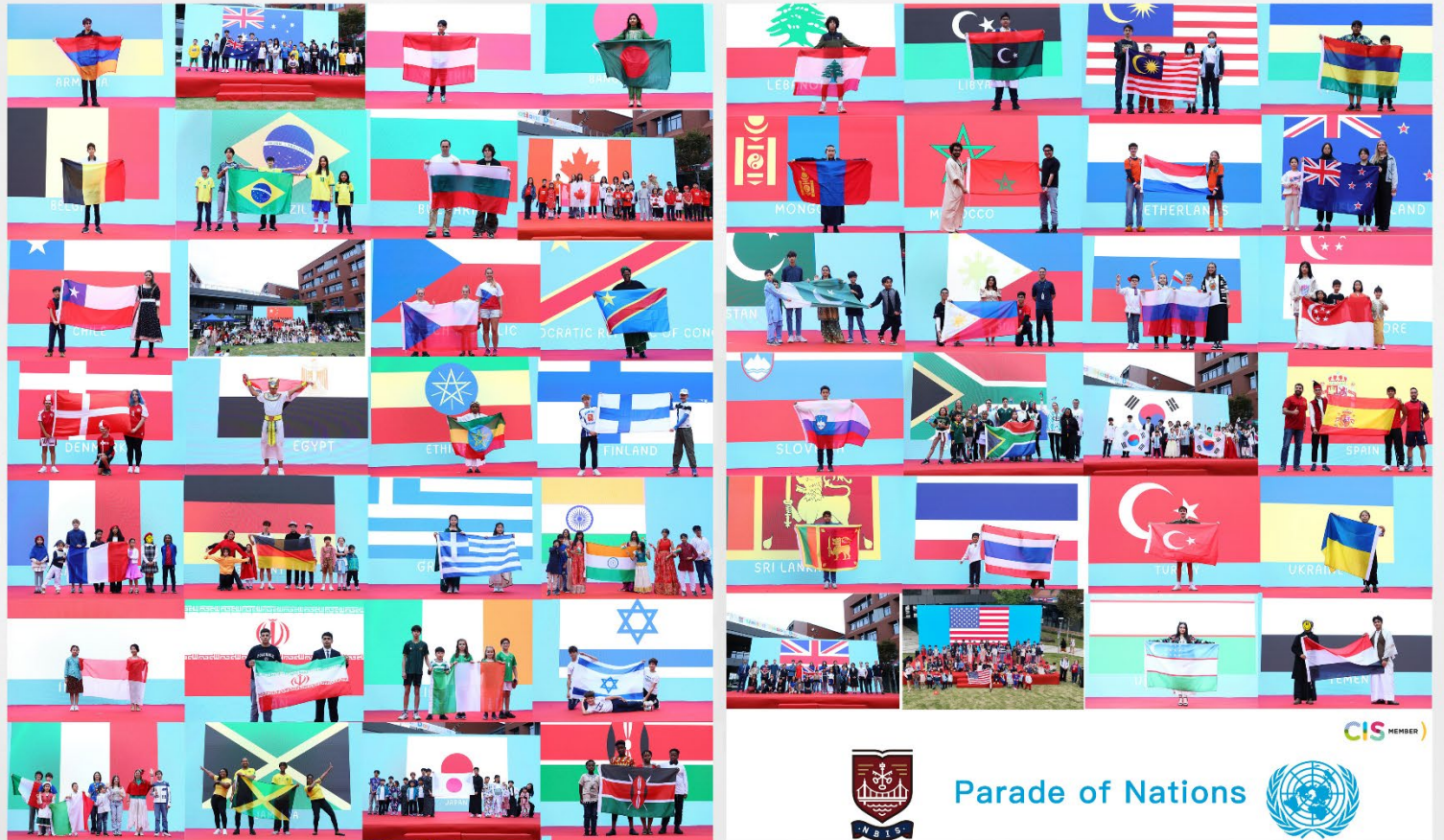

The event kicked off in the morning, with students, parents, and staff gathering on the lawn to watch the parade. This year's event was hosted by four outstanding students: Ariana Rutherford from Year 6 (United Kingdom), Ayesha Sajjad from Year 6 (Pakistan), Biel Das Cervera from Year 10 (Spain and India), and Zhui Rhee from Year 13 (Philippines and South Korea). They warmly welcomed representatives from various countries to the stage, sharing intriguing stories and cultural highlights that deepened the audience's understanding of each nation's unique charm. Students proudly donned traditional costumes and confidently carried their flags as they took to the stage, showcasing their pride and sense of belonging to their cultures.

In addition to the parade, the day was filled with a variety of captivating performances. Students from different countries showcased the artistic essence of their diverse cultures through dance, instrumental performances, and singing.

# PERFORMANCES & SPEECH

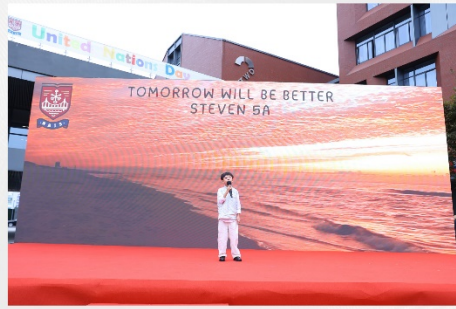

The parents of NBIS provide significant support for the school's various activities each year, especially during celebrations like UN Day, where they actively participate in organizing and preparing events. At the World Buffet, parents bring a rich array of delicacies from around the world, adding vibrant flavours to the UN Day celebrations. We extend our heartfelt thanks to the parents of NBIS for their selfless dedication and enthusiastic support, which make each year's UN Day even more splendid and successful.





# WORLD BUFFET



Dennis Liu, a Year 13 student from the United States, shared his thoughts on the event. He expressed that this year's UN Day celebration allowed him to deeply appreciate the diversity and unity within the NBIS community. He said, "It's really lively today and wonderfully diverse. We're able to showcase the uniqueness that NBIS brings to the Ningbo community. For students like myself, it's a great opportunity to learn about other cultures."

Meanwhile, Pariza Kishore, a Year 6 student from Australia, also shared her perspective. She enthusiastically remarked, "The performances are truly amazing! The Indian dance and the Latin dance are my favorites. We get to see people dancing and singing, and we get to hear different languages. It's really cool!"



The NBIS UN Day once again demonstrated the power of diversity and inclusion. Through vibrant activities, participants not only deepened their understanding of different cultures but also forged closer connections during the celebration. Whether they were parents, students, or teachers, everyone felt a sense of warmth and unity in this celebration. We look forward to next year's UN Day, where we will create even more beautiful memories together.

Finally, we would like to extend our heartfelt gratitude to all the members of the UN Day Committee and the entire NBIS faculty for their support and hard work in making this event a success. Thank you!



# PINK DAY

OCTOBER IS BREAST CANCER  
AWARENESS MONTH

Dear NBIS community,

In honour of Breast Cancer Awareness Month, the Secondary Student Council has decided to raise funds for One World One Dream (OWOD), a local organization formed in partnership with the Ningbo Charity Federation that helps local women battling breast cancer. On Monday, October 28th, the NBIS family from Early Years to Year 13 is invited to wear pink to show their support.

Pink Day is optional and involves a 10RMB donation; students may wish to donate more. Students are requested to give donations to their homeroom teachers in cash. After collecting all donations, the Secondary Student Council will count the money and pass all funds to OWOD.

NBIS are looking forward to carrying on the Pink Day tradition this year. Here are some photos from past Pink Day events:

**亲爱的NBIS社区：**

为了纪念乳腺癌宣传月，学生会决定为“同一个世界同一个梦想”(OWOD) 筹集资金，这是一个与宁波市慈善总会合作成立的当地组织，旨在帮助女性对抗乳腺癌。10月28日星期一，NBIS邀请全校师生穿着粉红色衣服以表达我们的支持。

粉红日是自愿参与，需要捐款10元；如果学生愿意，不妨捐赠更多。请学生向班主任捐款现金。所有捐款筹集完毕后，将转交给OWOD。

NBIS期待今年继续延续粉红日的传统。以下是过去粉红日活动的一些照片：



# 28TH OCTOBER



## BREAST CANCER AWARENESS MONTH



NBIS宁波英伦外籍人员子女学校



NBIS宁波英伦外籍人员子女学校



# Reception A

Ms Samy & Ms Echo

## Exploring Traditional Tales: A Month of Creativity and Collaboration

This month, our school has embarked on an enchanting journey into the world of "Traditional Tales." Students had the opportunity to explore beloved stories like "The Three Little Pigs" and "Goldilocks and the Three Bears," immersing themselves in the lessons and values these timeless tales impart.

As part of the theme, our young learners engaged in a delightful hands-on activity that brought the stories to life. After reading about Goldilocks' adventures, students rolled up their sleeves to make their own porridge, gathering in the kitchen to create this simple yet classic dish. It was a wonderful way for them to connect with the story and experience one of Goldilocks' favourite foods!



Additionally, the students were divided into groups to engineer their own houses inspired by "The Three Little Pigs." Using a variety of materials, they constructed their representations of the straw, stick, and brick houses found in the tale. This activity not only sparked their creativity but also encouraged important life skills. As they collaborated to design and build their houses, they learned the value of teamwork, resourcefulness, and problem-solving.

Through these engaging activities, students developed a deeper understanding of teamwork and creativity, as well as an appreciation for stories that have been passed down through generations. Our exploration of traditional tales has fostered valuable skills and unforgettable memories for our students that they will carry with them.

We look forward to continuing this literary adventure and uncovering more lessons from the tales that inspire us all!



# Congratulations to Our Stars of the Week



**Y4A - James & Olivia**

**Y4B - Pepper & Brian**

**Y5A - Alicia & Bruno**

**Y5B - Andrew & Tim**

**Y5C - Candice & Ryan**

**Y6A - Ayush, Tiffany, Marvin, Joyce**

**Y6B - Ariana, Sasha & Leah**

**Well done our stars, your hard work, positive attitude,  
and kindness make NBIS a better place every day.  
Keep shining brightly and inspiring others with your  
amazing efforts. We're so proud of you!**

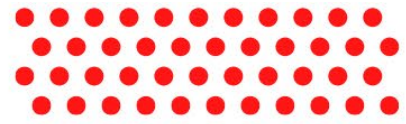

# ESL Beginner Group



Ms Emily Ye

This week, we have been exploring the English language through various engaging activities, games, and projects. The lesson engages children as active, creative learners with opportunities to participate in a wide variety of curriculum-based activities to acquire content knowledge and develop critical thinking skills.



nouns: are naming words			
<b>People</b> Ms Emily Elsa	<b>Animals</b> tiger bear	<b>Things</b> chair pizza	<b>Places</b> NBIS China
verbs: are action words			
<b>Actions</b> fix make	<b>Actions</b> knock climb	<b>Actions</b> eat hide	<b>Actions</b> laugh feel



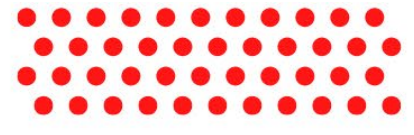

# ESL Beginner Group



Our classroom is a safe and supportive environment where students can feel comfortable to ask questions, make mistakes, and learn from each other.

Using sentence starters can increase students' confidence in their English abilities, as they are more likely to produce correct sentences, receive positive feedback, and engage more in class discussions.

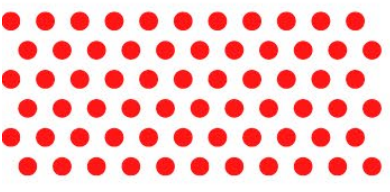
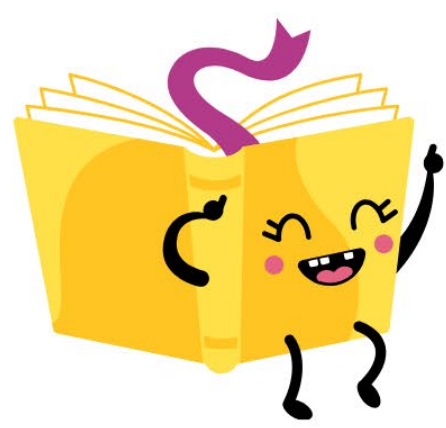
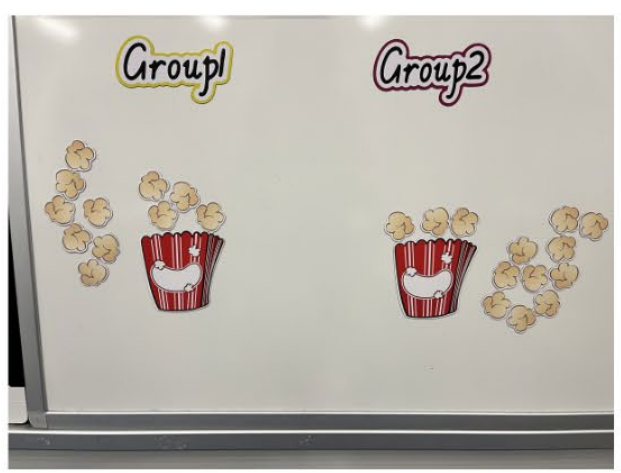

# Upcoming Events

Primary Student Council

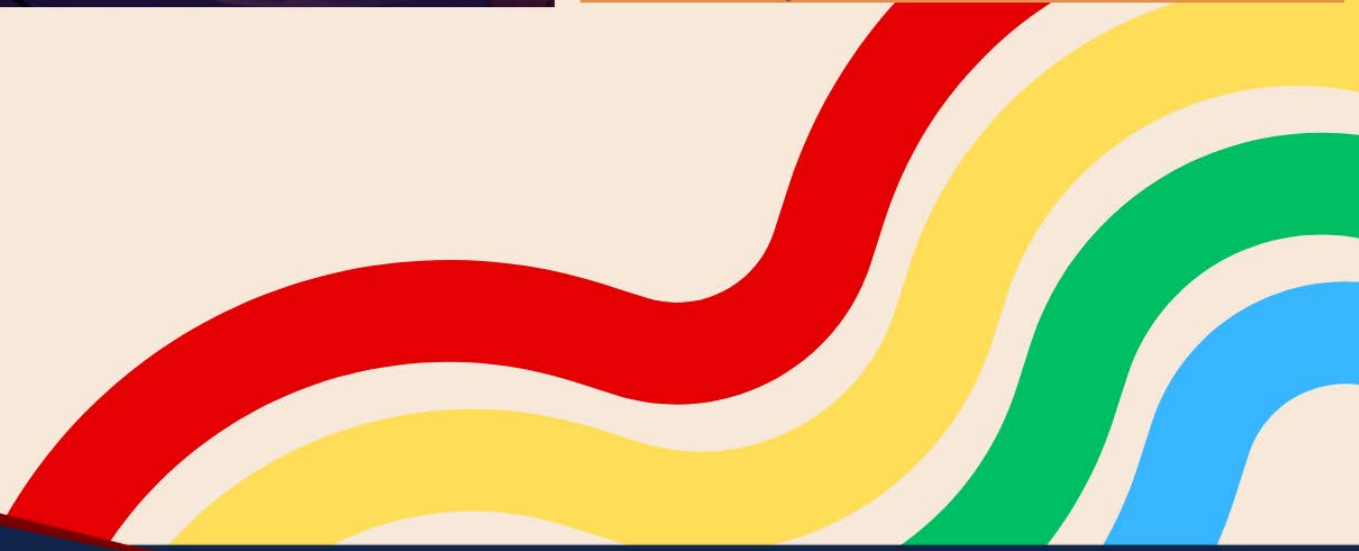
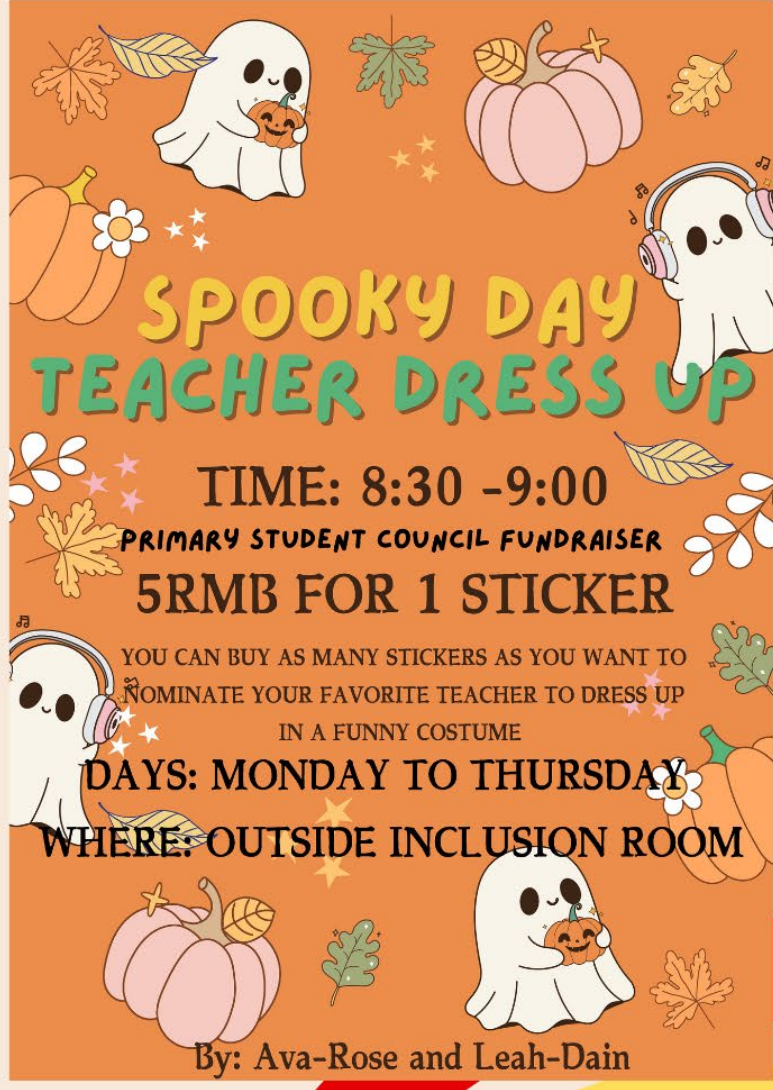

# Secondary Ted Talk Competition at NBIS

Ms Alicia Froome  
Head of Department - English

On Monday, October 21st, the Ningbo British International School Secondary English Department organised an event called the NBIS Ted Talk Competition, which has a similar style to the official TED Talks you have seen. TED, founded in 1984, stands for 'Technology, Entertainment, and Design'. Instead of just watching TED talks, NBIS students created their own. Students from Year 7 to Year 10 were tasked with creating their own Ted-style Talk to educate and entertain their peers.



The topics the students chose were inspired by the TED Talk genre and based on an idea worth spreading. Students created their talks with the help of their respective English class teachers. The teachers helped them choose appropriate topics, plan their speech, and write their speech using persuasive language techniques. Then, Ms Nausicaa and Mr Sean Armstrong, the drama teachers, helped to coach students on presenting their speech and working on their performance skills.



During the event, each student performed brilliantly. The audience listened intently and truly learned something from each and every speaker.

**Types of Multiverses**

Types of Multiverse:  
 - Parallel Universes: Nearly Identical Universes  
 - Bubble Universes: Different Physical Laws

WE ARE HERE!

The Multiverse Theory  
Liam Ronen (Year 10A)

**OPEN MINDED CURIOSITY**

Life and Living  
Charlie Morris (Year 10A)

**SPEAKING SKILLS**

By Dylan 9A

Speaking Skills  
Dylan Towey (Year 9A)

**0.62 %**

In every 160 children will have 1 kid is "the star's children"

What Are the Benefits of Autism?  
Zoe Xu (Year 8B)

**AMEER ISFAHAN**

My Unusual Dream  
Ameer Isfahan (Year 7)

**The Inside Story of AI**

Cherry Xu (Year 7)

**Types of diseases spread by poor quality drinking water.**

Hepatitis	7%
Hair Disease	10%
Typhoid	11%
Dengue Fever	22%
Diarhea	42%

Marine Pollution  
Kiana Bian (Year 7)



NBIS Students gained persuasive writing skills and dared to stand in front of the audience and explain their ideas logically. Congratulations to Dylan Towey of Year 9, who impressed the audience with his talk on public speaking skills.



NBIS encourages students to enhance their knowledge through competitions like the 'NBIS Ted Talk'. As we look ahead to next time, we eagerly anticipate even greater participation from our students, who will bring fresh perspectives and exciting performances to the stage. We believe that these contributions will not only enrich the competition but also foster a vibrant exchange of ideas, showcasing the diverse talents and creativity of our community.



In art class, students delved into the rich history of Venetian masks, learning about their cultural significance during Carnival and their evolution over centuries. They explored the symbolism behind various mask designs, such as the Bauta, Zanni, and Joker, and how these masks were used for anonymity, social satire, and theatrical performances. Inspired by this tradition, students created their own paper masks, first constructing a base design and then applying layers of papier-mâché to give the masks form and durability. Once dried, they painted their masks with vibrant colors and patterns, emulating the intricate details of traditional Venetian masks. To finish, students used pens to add fine decorative elements, bringing their unique creations to life while reflecting on the history they studied.

**Ms.Sam, Secondary Art & Design Teacher**

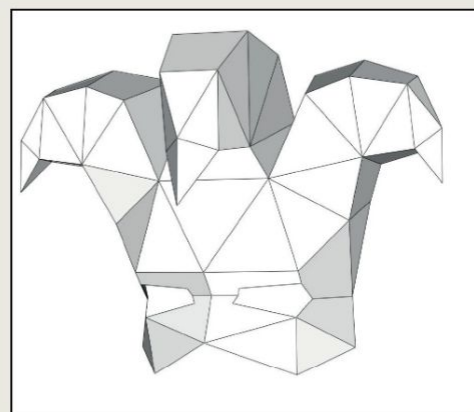
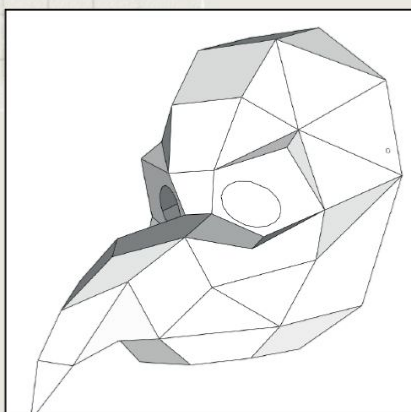
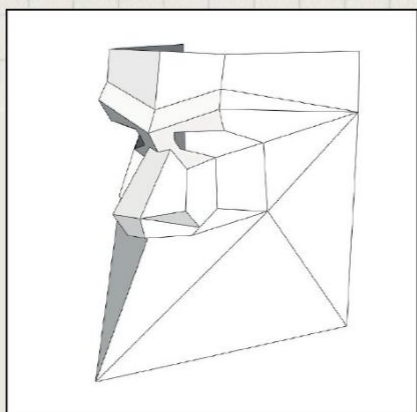

Secondary  
Section

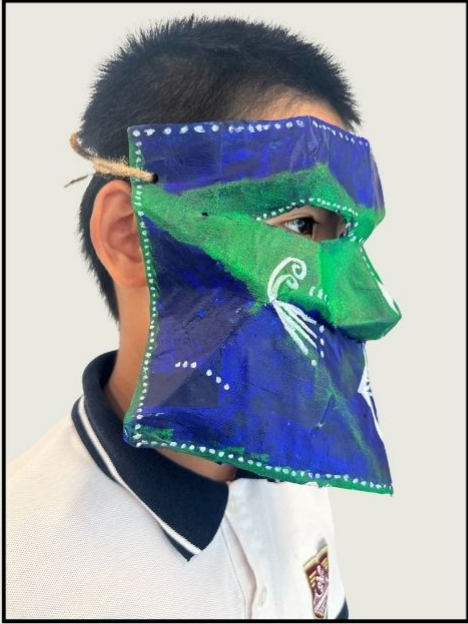



# TINKERCAD

## \* 3D DESIGN SKILLS

Mr John Helmy

### WHAT IS TINKERCAD

Tinkercad is a free, web-based application that allows users to create 3D models by manipulating shapes and objects in a virtual workspace. It's user-friendly, making it ideal for beginners, while still offering the potential for complex and detailed designs. Recently lower secondary students have been utilising Tinkercad in a range of design projects. These kinds of projects encourage hands-on learning and show students that their creative ideas can come to life in a digital space.

### SKILLS STUDENTS CAN LEARN

Using Tinkercad fosters several important skills that students will benefit from both academically and in future careers:

- Problem-Solving
- Spatial Awareness
- Creativity and Innovation
- Collaboration



### WHY 3D DESIGN IS IMPORTANT

Learning 3D design at a young age sets the foundation for understanding advanced concepts in fields such as architecture, engineering, and product design. As students engage with digital tools like Tinkercad, they gain confidence in using technology, enhancing their ability to adapt to new platforms and software in the future. More importantly, 3D design is a hands-on way for students to bridge the gap between abstract ideas and tangible results, promoting deep learning and engagement.





## 3D PRINTING

NBIS owns several industrial quality 3D printers allowing students to output their 3D designs into physical models. This also opens students' minds up to the manufacturing process involved in creating from digital designs.

## PREPARING FOR THE FUTURE

Incorporating Tinkercad into our curriculum helps ensure that students are prepared for the technology-driven careers of tomorrow. 3D design skills are becoming increasingly valuable across a wide range of industries, including:

- Engineering and Architecture
- Animation and Game Design
- Medical Fields
- Manufacturing and Product Development.

At NBIS, we are proud to offer our students the opportunity to learn cutting-edge skills that will serve them in the future.

## HOUSES BUILT BY STUDENTS

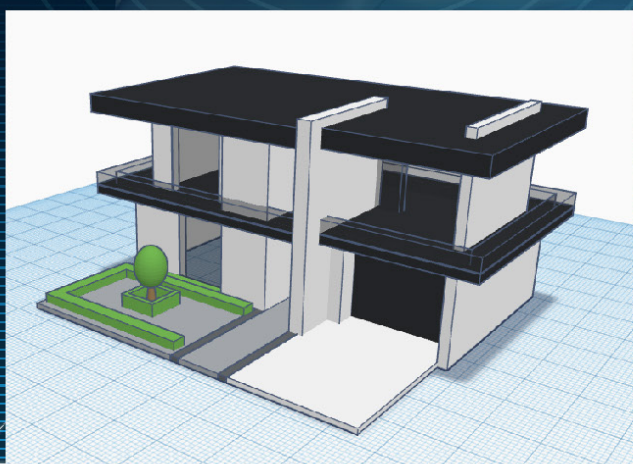

YEAR 9 ANVI



YEAR 9 DEAN

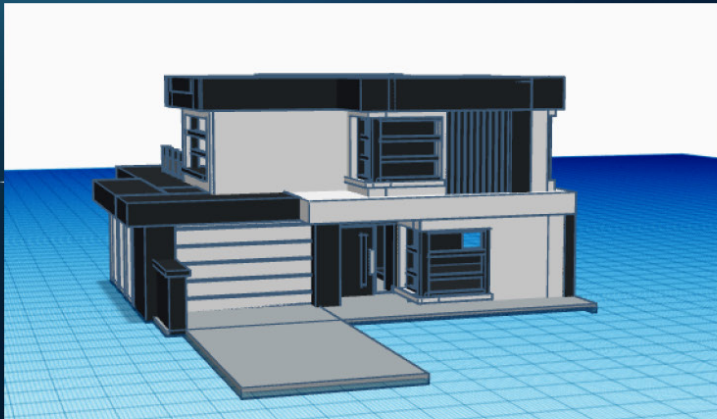

YEAR 9 SIMONE

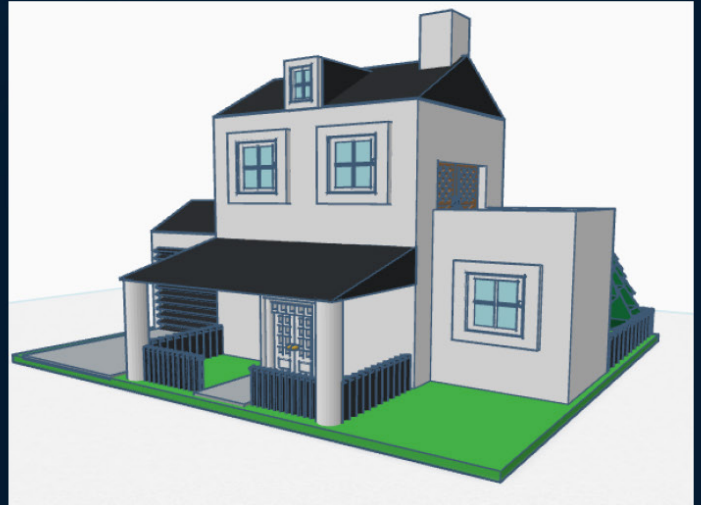

YEAR 9 DYLAN

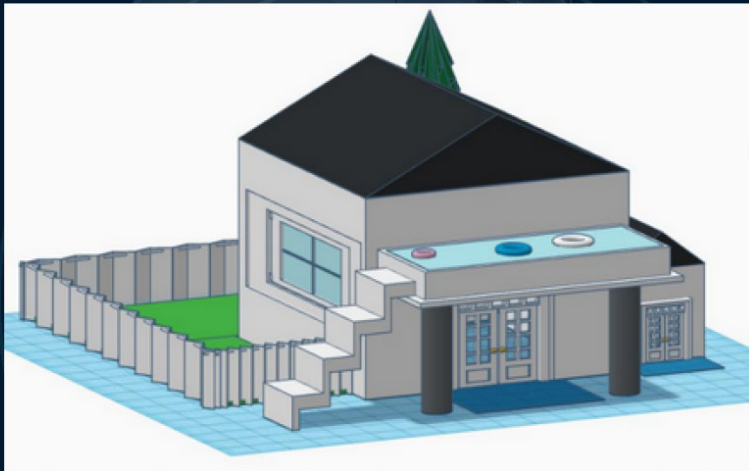

YEAR 9 BRAXTON



YEAR 9 BRUCE

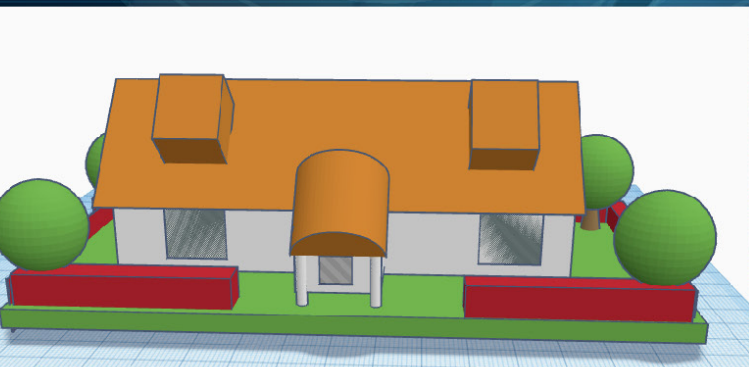

YEAR 9 SHARON

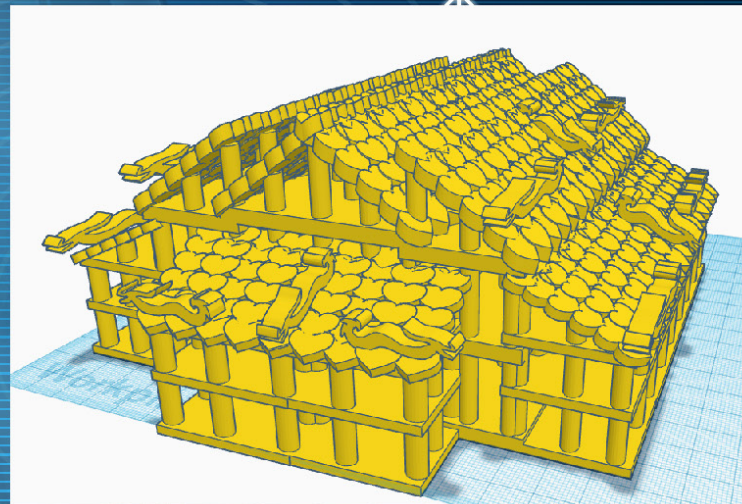

YEAR 9 JUSTIN



# TINKERTOBER 3D MODEL COMPETITION



**Do you have a frightfully great idea for a  
spooky 3D model!!!**

Open to all students from years 7-13

See Mr. Helmy or Mr. Pollitt to learn more  
about 3D design and printing

Final submissions  
Friday, 1st November 2024

NINGBO BRITISH INTERNATIONAL  
SCHOOL

# SPIRIT WEEK

OCT 28TH - NOV 1ST

"Have fun and  
participate"

**Monday:**  
Pink Day

**Tuesday:**  
Cosplay Day

**Wednesday:**  
Anything But A  
Backpack Day

**Thursday:**  
Spooky Thursday

**Friday:**  
Casual Friday

For more information, ask any members  
or student council or Ms Froome:



SECONDARY STUDENT COUNCIL  
SPIRIT WEEK 2024-2025

# PINK DAY

DRESS IN PINK  
FOR BREAST  
CANCER  
AWARENESS  
MONTH

MONDAY  
**28TH**  
OCTOBER



**10 RMB**

ALL PROCEEDS GO TOWARDS OWOD (NINGBO)

# COSPLAY DAY

TUESDAY, OCTOBER 29 TH

DRESS UP AS A CHARACTER FROM A  
FILM, ANIME, BOOK OR VIDEO GAME

SECONDARY STUDENT COUNCIL  
SPIRIT WEEK 2024-2025

**10 RMB**



# ANYTHING BUT A BACKPACK DAY

WEDNESDAY  
**OCTOBER**  
30th

**10 RMB**

Example: Basket or Box

Bring your school  
books and supplies in  
anything but a  
backpack

DON'T MISS  
THE  
CHANCE!

SECONDARY STUDENT COUNCIL SPIRIT WEEK 2024-2025

OCTOBER  
31<sup>ST</sup>

**10 RMB**

# SPOOKY THURSDAY

DRESS UP IN A SPOOKY OUTFIT!

SECONDARY STUDENT COUNCIL  
SPIRIT WEEK 2024-2025



# CASUAL FRIDAY

NOVEMBER 1ST



IT IS ALMOST THE WEEKEND!  
DRESS UP IN YOUR CASUAL CLOTHES



10 RMB

SECONDARY STUDENT COUNCIL SPIRIT WEEK 2024-2025

## The new POINT SYSTEM FOR A SPECIAL PRIZE

BE A WINNER

OCTOBER 28TH - NOVEMBER 1ST

BE THE BEST CLASS

DAY	DATE	POINT PER PERSON PARTICIPATING IN EACH YEAR
1	Monday 28th, Pink Day	1
2	Tuesday 29th, Cosplay Day	1
3	Wednesday 30th, Anything But A Backpack Day	1
4	Thursday 31st, Spooky Thursday	1
5	Friday 1st, Casual Friday	1

Plus 5 points to the winners of each dressup day for every year (e.g. Year 7, Year 8...)

STUDENT COUNCIL PRESENTS NEW REWARD SYSTEM

# WINNING CLASS

ANNOUNCED ON : NOVEMBER 4TH

WIN THE GRAND PRIZE!

# NO UNIFORM DAY

NBIS STUDENT COUNCIL





**University of Nottingham**  
UK | CHINA | MALAYSIA



# UNNC Robotics School 2024 (Basic Level)

## Event Dates:

November 23 and 30, 2024.

## Total No. of Students:

20

**First Come  
First Serve**

## Leading faculty member:

Luke Chang (NUBS China),  
David Chieng (FoSE)

## Host Organization:

Ingenuity Lab, UNNC

## Target Audience:

Secondary students (Grade 10 and above) from international schools in the Greater Ningbo area or UNNC alumni's families

## What You Can Get:

Experience STEM education and robotics, inspiring you to pursue careers and learn skills in programming and robotics.

## Admission Requirements:

- Student ID
  - Letter of Interest: A short letter (about 200 words) explaining their motivation and interest
- Please send above material to [Yaru.He@nottingham.edu.cn](mailto:Yaru.He@nottingham.edu.cn) **before 2nd November** for review.



## Certificate & Awards:

- Certificate of Completion: Students who successfully complete the school will receive a certificate from the Ingenuity Lab, UNNC.
- Competition Prizes: Students will have the chance to win: 1st Prize, 2nd Prize, 3rd Prize

## Robotics School Curriculum

Basic level Robotics Exercise

(Total 12 hours)

- LEGO® MINDSTORM

Intermediate level Robotics Exercise

(Total 12 hours)

- DOBOT Robot Arm

Advanced level Robotics Exercise

(Total 12 hours)

- Humanoid and Dog robots





# NBIS Weekly Menu



Sample Dishes





**NBIS Weekly Menu**  
**The Week of October 28th to November 1st, 2024**

	Monday	Tuesday	Wednesday	Thursday	Friday	
<b>Lunch Menu</b>	Chicken popcorn	Roast chicken wing	Crispy chicken cutlet	Chicken wing	Fried Fish Fillet	
	鸡米花	烤鸡翅	鸡排	芝麻翅根	炸鱼排	
	Rib with taro	Curry chicken	Mushroom with meat	Braised pork	Spiced Beef	
	香芋仔排	椰蓉咖喱鸡	香菇蚝油肉片	红烧肉	酱牛肉	
	Roast duck	Stewed pork with sauce	Shredded chicken	Shrimp with celery	Chicken with corn	
	烤鸭	卤肉	手撕鸡	西芹虾仁	玉米鸡丁	
	Cauliflower	Broccoli	Egg tart	Potato	Roast potato	
	花菜	西兰花	蛋挞	椒盐土豆	烤土豆	
	Scrabbled egg with tomato	Roast sweet potato	Cauliflower	Broccoli	Cauliflower	
	西红柿炒蛋	烤地瓜	花菜	西兰花	花菜	
	Roast potato	French bread	Chinese noodle	Cabbage	Croissant	
	烤土豆	法式面包	三丝炒面	大白菜	牛角包	
	Pearl milk tea	Cabbage	Potato with onion	Pizza	Roasted rice cake with vegetable	
	奶茶	包菜	洋葱土豆片	披萨	天菜年糕	
	Fruit	Fruit	Fruit	Fruit	Fruit	
	水果	水果	水果	水果	水果	
	Poached Shrimp	Salt and Pepper Shrimp	Sichuan-style beef with duck blood curd	Lotus root slices	Braised Fish slice	
	盐水虾	椒盐虾	毛血旺	烤藕片	红烧鱼块	
	Fish	Fish with Chopped Bell Pepper	Fried Shrimp	Shrimp with Soy Sauce	Poached Shrimp	
	姜蒸玉兔鱼	剁椒鱼	油爆虾	红烧虾	盐水虾	
	Pork slices	Pork slices	Steamed Pomfret	Fish	Pork with Chopped Bell Pepper	
	水煮肉片	尖椒肉片	葱油鲳鱼	小黄鱼	泡椒肉片	
	Vegetable soup	Tomato soup with egg	Tofu and cabbage soup	Snow Fungus and Red Date Soup	Seaweed soup with egg	
	万年青汤	西红柿蛋汤	白菜豆腐汤	银耳红枣汤	紫菜蛋花汤	
	Rice	Rice	Rice	Rice	Rice	
	米饭	米饭	米饭	米饭	米饭	
	Vegetable	Vegetable	Vegetable	Vegetable	Vegetable	
	蔬菜拼盘	蔬菜拼盘	蔬菜拼盘	蔬菜拼盘	蔬菜拼盘	
	<b>Snack Menu</b>	Watermelon	Banana	Cherry tomato	Muskmelon	Nectarine
		西瓜	香蕉	小番茄	小甜瓜	油桃
		Omelette	Dumpling	Egg	Dumpling	Turnip strips cake
		鸡蛋饼	蒸饺	水煮蛋	蒸饺	萝卜丝饼
Pear		Orange	Apple	Longan	Cucumber	
香梨		桔子	苹果	桂圆	小青瓜	
Bread with jam		French bread	Pizza	Egg tart	Croissant	
土司面包+果酱		法式面包	披萨	蛋挞	牛角包	





Aug 2024						
M	T	W	T	F	S	S
			1	2	3	4
5	6	7	8	9	10	11
12	13	14	15	16	17	18
19	20	21	22	23	24	25
26	27	28	29	30	31	

Sep 2024						
M	T	W	T	F	S	S
						1
2	3	4	5	6	7	8
9	10	11	12	13	14	15
16	17	18	19	20	21	22
23	24	25	26	27	28	29
30						

Oct 2024						
M	T	W	T	F	S	S
	1	2	3	4	5	6
7	8	9	10	11	12	13
14	15	16	17	18	19	20
21	22	23	24	25	26	27
28	29	30	31			

Nov 2024						
M	T	W	T	F	S	S
				1	2	3
4	5	6	7	8	9	10
11	12	13	14	15	16	17
18	19	20	21	22	23	24
25	26	27	28	29	30	

Dec 2024						
M	T	W	T	F	S	S
						1
2	3	4	5	6	7	8
9	10	11	12	13	14	15
16	17	18	19	20	21	22
23	24	25	26	27	28	29
30	31					

Jan 2025						
M	T	W	T	F	S	S
		1	2	3	4	5
6	7	8	9	10	11	12
13	14	15	16	17	18	19
20	21	22	23	24	25	26
27	28	29	30	31		

Feb 2025						
M	T	W	T	F	S	S
					1	2
3	4	5	6	7	8	9
10	11	12	13	14	15	16
17	18	19	20	21	22	23
24	25	26	27	28		

Mar 2025						
M	T	W	T	F	S	S
					1	2
3	4	5	6	7	8	9
10	11	12	13	14	15	16
17	18	19	20	21	22	23
24	25	26	27	28	29	30
31						

Apr 2025						
M	T	W	T	F	S	S
	1	2	3	4	5	6
7	8	9	10	11	12	13
14	15	16	17	18	19	20
21	22	23	24	25	26	27
28	29	30				

May 2025						
M	T	W	T	F	S	S
			1	2	3	4
5	6	7	8	9	10	11
12	13	14	15	16	17	18
19	20	21	22	23	24	25
26	27	28	29	30	31	

Jun 2025						
M	T	W	T	F	S	S
						1
2	3	4	5	6	7	8
9	10	11	12	13	14	15
16	17	18	19	20	21	22
23	24	25	26	27	28	29
30						

Jul 2025						
M	T	W	T	F	S	S
	1	2	3	4	5	6
7	8	9	10	11	12	13
14	15	16	17	18	19	20
21	22	23	24	25	26	27
28	29	30	31			

**2024-25 Semester 1** (School Days-90 Days)

26/08/2024 Semester 1 Begins, 14/02/2025 Semester 1 Ends

**Holidays in Semester 1**

- 14/09/2024 to 17/09/2024 Mid-Autumn Festival
- 28/09/2024 to 07/10/2024 Chinese National Holiday
- 22/11/2025 PD Day
- 18/12/2024 to 05/01/2025 Winter Holiday
- 22/01/2025 to 09/02/2025 Spring Festival Holiday

**2024-25 Semester 2** (School Days-90 Days)

17/02/2025 Semester 2 Begins, 01/07/2025 Semester 2 Ends

**Holidays in Semester 2**

- 04/04/2025 to 06/04/2025 Qingming Holiday
- 28/04/2025 to 04/05/2025 Labour Day Holiday
- 30/05/2025 to 01/06/2025 Dragon Boat Holiday





# Ningbo British International School

## 浙江宁波英伦外籍人员子女学校

Unity - Diversity - Excellence

✉ [nbis.admin@nbis.net.cn](mailto:nbis.admin@nbis.net.cn)

☎ +86 57487611005

🌐 [www.nbis.net.cn](http://www.nbis.net.cn)

📍 No. 365 Guanghua Road,  
Hi-Tech Zone,  
Ningbo 315000



 **CAMBRIDGE**  
International Education

Cambridge International School